



# HH-47 CSAR

HEROES SAVED... FREEDOM PRESERVED



# HH-47 CSAR-X

Boeing's Combat Search and Rescue HH-47 is the most capable and versatile rotorcraft for the U.S. Air Force's CSAR requirement. The HH-47 incorporates a number of combat-proven advantages. These include the MH-47G capability of forward-looking infrared radar (FLIR), terrain following/terrain avoidance (TF/TA) radar, in-flight refueling, a net-ready cockpit, and maritime-type fuselage. Also included is a 52-inch-wide door with dual rescue hoist, blade de-ice, state-of-the-art electronic warfare system, environmentally controlled patient treatment area, enhanced health usage monitoring system (HUMS), and wire strike protection. These real-world performance capabilities are coupled with an active production line and established provider base. The result: the HH-47 CSAR is the best aircraft available to perform this critical Air Force mission and to ensure that, "heroes are saved and freedom is preserved".



## HH-47 CSAR-X Configuration

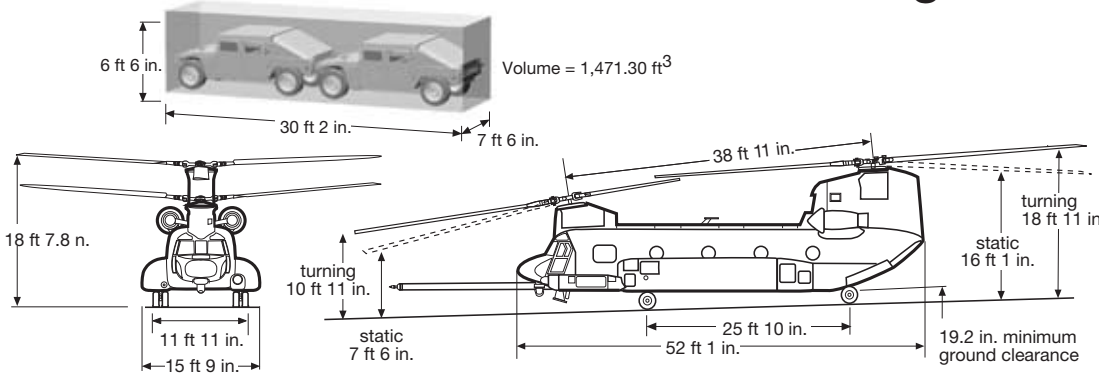

LENGTH:	
Rotors operating	98 ft 10.7 in
Rotors folded	52 ft 1 in
Fuselage	52 ft 1 in

HEIGHT:	
Overall	18 ft 7.8 in
Tread	11 ft 11 in

ROTOR DIAMETER: 60 ft

ROTOR GROUND CLEARANCE:	
Static forward	7 ft 6 in
Idling forward	10 ft 11 in

- Environmentally controlled patient treatment area
- Enhanced HUMS
- Enhanced air-transportability kit; demonstrated capability in under three hours
- Rotorbrake
- Flight into known icing conditions: engine anti-ice, blade de-ice, heated windshields
- Improved situational awareness and net capable
- Aerial refueling
- T55-GA-714A engines
- Shipboard operations
- Wire strike protection
- Day/night, adverse weather ops: FLIR, weather radar, TF/TA radar, digital air flight control system (DAFCS)
- Integrated electronics warfare and weapons suite
- Electromagnetic interference (EMI) hardening; nuclear, biological, chemical (NBC) protection
- Alternate insertion/extraction (AIE): fast rope, rope ladder, rappel, dual hoist rescue, STABO/SPIE
- Pilot/copilot crashworthy seats with restraint systems; stowable and crashworthy seats with restraint systems for all passengers and crewmembers

**The Boeing Company**  
P.O. Box 16858  
Philadelphia, PA 19142-0858

Contact: Clinton V. Horn  
Telephone: 610.858.0322  
Email: clinton.v.horn@boeing.com

Richard Spicer  
610.742.2504  
richard.k.spicer@boeing.com

www.boeing.com  
BOEING is a trademark of Boeing Management Company.  
Copyright ©2006 Boeing. All rights reserved.  
53397-02